

SETTING THE LOW CUT AND PHANTOM POWER SWITCHES  
On the left side are the Phantom Power and Low-Cut switches.

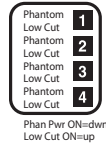

As shown here, under each number is a P indicating Phantom Power, and an L which indicates Low-Cut. When the P switch is DOWN, the phantom power is ON, when it is UP the phantom power is OFF. When the L switch is UP, the low-cut is ON, when it is DOWN, the low-cut is OFF.

# ROLLS

## MX124 ProMix IV



### SPECIFICATIONS

Input Impedance:	600 Ohms
Output Impedance:	XLR 600 Ohms, 1/4" and 1/8" 10 Ohms
THD + Noise:	.02%
S/N Ratio:	84 dB
Frequency Response:	25 Hz - 16 kHz (+0 / -3 dB)
Max Output Level:	+14 dB
Max Input Level:	-14 dB
Max Gain:	+55 dB
Low Cut:	-3 dB @ 100 Hz
Current Draw:	30 mA
Phantom Power:	+18 VDC
Connectors:	4 Female XLR, 2 Male XLR, 1 1/4" TRS, 1: 1/8" (3.5mm) DC Power Jack (5.5 X 2.1 mm tip negative)
Size:	6.3" w x 3.7" d x 2.3" h
Weight:	1.5 lbs.

# INTRODUCTION

Thank you for your purchase of the MX124 ProMix IV. This unit is designed and manufactured to mix four microphones together and send their combined signals out stereo transformer-balanced XLR outputs, or front panel 1/4" and 1/8" stereo outputs. The individually switchable phantom power and low-cut switches provide the final touches which make the MX124 a valuable tool for any sound reinforcement, musical, recording, or install application.

## INSPECTION

1. Unpack and Inspect the MX124 package  
Your MX124 was carefully packed at the factory in a protective carton. Nonetheless, be sure to examine the unit and the carton for any signs of damage that may have occurred during shipping. If obvious physical damage is noticed, contact the carrier immediately to make a damage claim. We suggest saving the shipping carton and packing materials for safely transporting the unit in the future.

2. Please visit our website at [www.rolls.com](http://www.rolls.com), click on the Register Your Warranty Here text and follow the instructions to register your MX124. Or complete the Warranty Registration Card and return it to the factory.

## DESCRIPTION REAR PANEL

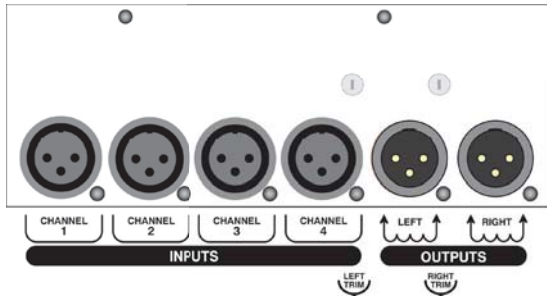

Mic Input: 1 - 4: XLR balanced inputs for connection to any standard dynamic or condenser microphone.  
Right and Left Outputs: Transformer balanced XLR output jacks for connection to the next device in the signal chain such as a signal processor or amplifier.  
Right and Left Trim controls: Screwdriver adjustable controls to vary the level of each output. Turning these controls clockwise increases the output level. These controls do not effect the Aux/Headphone Output.

## FRONT PANEL



Mic Level 1 - 4: These controls adjust the level of the corresponding Mic channel. The level varies from -infinity (off) to max gain.  
PAN 1 - 4: Adjusts the relative right/left level of each channel.

Phone/Aux: 1/4" and 1/8" (3.5mm) TRS jacks which may be connected to a pair of headphones for personal monitoring, or to a stereo unbalanced input of a signal processor, amplifier, or camera.  
Clip LED: Indicates that clipping is about to occur or occurring in the MX54s circuitry. This LED begins to light 3dB below actual circuit clipping.

## RIGHT HAND SIDE

- Battery compartment which houses two 9-Volt (alkaline recommended) batteries.
- VDC power jack for connection to the Rolls PS27s; VDC (outside of the ring is positive) external power supply.
- Power Switch: Applies power to the MX124.

## SCHEMATIC

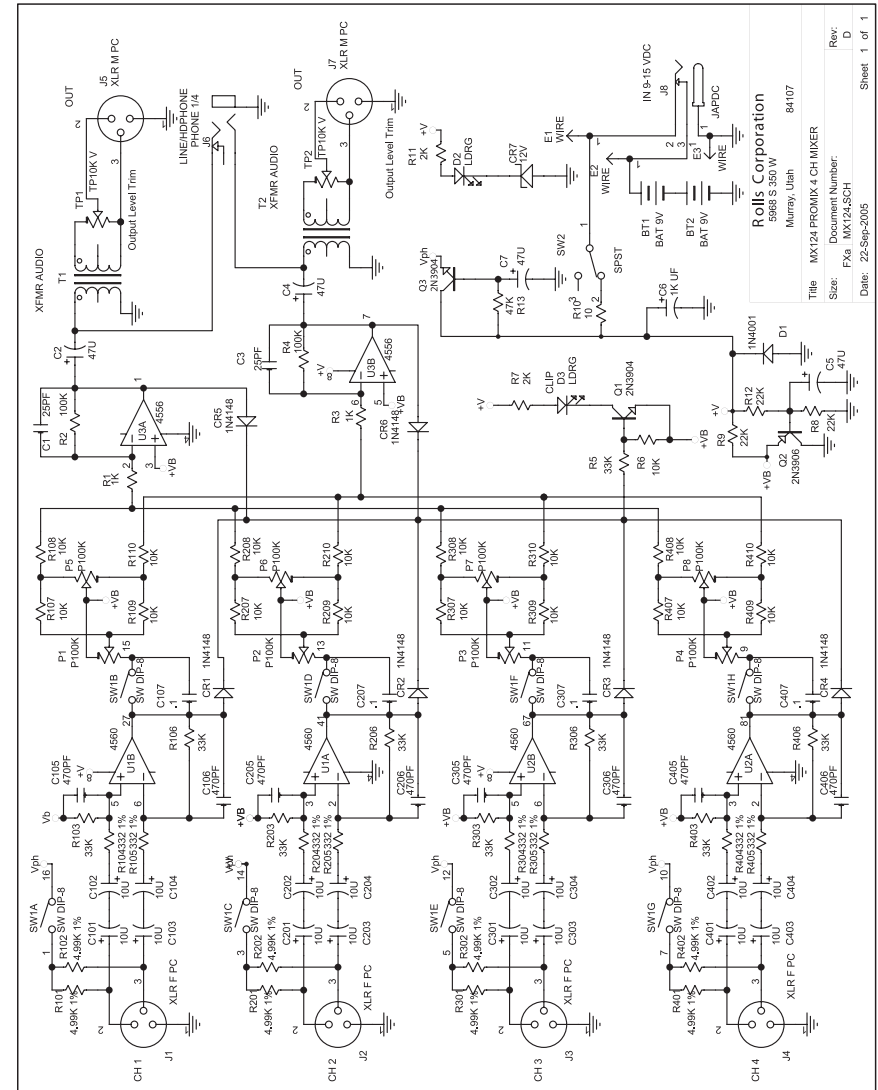

**Rolls Corporation**  
5988 S 550 W  
Murray, Utah 84107  
Title: MX124 PROMIX 4 CH MIXER  
Size: FXa MX124 SCH  
Date: 22-Sep-2005  
Rev: D  
Sheet 1 of 1